

Type AA - Female Threads
Typ AA - Innengewinde
Tip AA - Filet femelle
Tipo AA - Rosca hembra

Techn. Data

Typ	Q max.	P max.
BV3 (1½")	800 l/min 208 US gpm	100 bar 1500 psi
BV5 (2½")	1600 l/min 416 US gpm	70 bar 1030 psi

Type ED - Swivel Nut
Typ ED - Überwurfmutter
Type ED - Erou raccord
Tipo ED - Tuerca loca

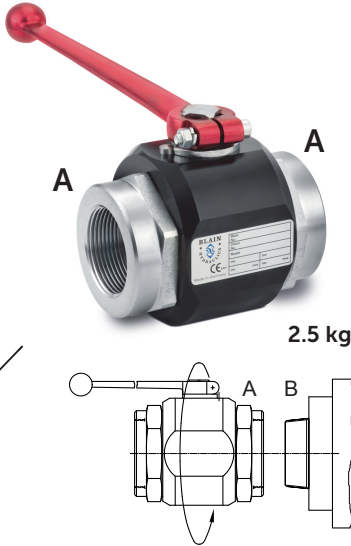

Standard A - A

Pipe Thread
Seal Tape Required
Rohrgewinde
Dichtband notwendig
Filetage au pas du gaz Bande d'étanchéité nécessaire
Rosca para tubos
Se necesita cinta de junta

Option E - D

Faster Connections
Perfect Sealing
Schnelle Montage
Perfekte Dichtung
Montage rapide
Joint parfait
Montaje rápido
Estanqueidad perfecta

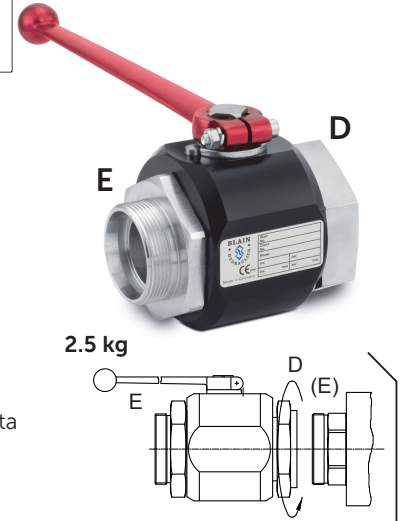

A

Typ	A	AF*	(BSP)		(NPT)	
			Typ No.	LA	Typ No.	LA
B3	1"	70	B3G1	19	B3N1	28
	1¼"	70	B3G1.25	21	B3N1.25	28
	1½"	70	B3G1.5	24	B3N1.5	34
	2"	70	B3G2	30	B3N2	34
B5	2"	95	B5G2	31	B5N2	31
	2½"	95	B5G2.5	31	B5N2.5	35

Standard

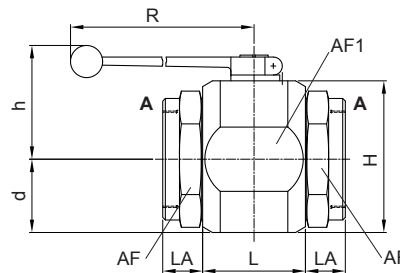

Dimensions

Typ	DN	L	H	AF1	d	h	R
B3	38	65	90	86	43	70	240
B5	55	80	118	114	57	82	280

DN = Ø Inside · Ø Innen
Ø Intérieur · Ø Interior

E

DIN 2353 (24°)

DIN 3863 (60°)

Typ	E	α	LE	*AF	Typ No.
B3	M36x2	24°	24.5	70	B3E36
	M45x2	24°	26.5	70	B3E45
	M52x2	24°	26.5	70	B3E52
	M65x2	60°	27	70	B3E65
B5	M78x2	60°	35	95	B5E78

Option

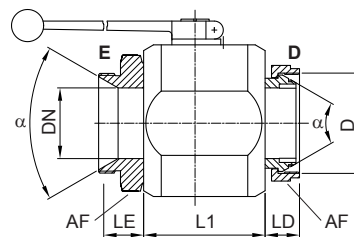

D

DIN 2353 (24°)

DIN 3863 (60°)

Typ	D	α	L1	LD	*AF	Typ No.
B3	M52x2	24°	66	35	60	D52
	M65x2	60°	66	25	75	D65
B5	M78x2	60°	94	24	90	D78

Adaptor BD

Typ	D	B	*AF	LD	Typ No.
B3	M65x2	G1½"	70	47	BD65.G1.5
	M65x2	Ø57 Weld	70	45	BD65.57
B5	M78x2	G2"	90	48	BD78.G2
	M78x2	Ø70 Weld	90	44	BD78.70

*AF - Across Flats
AF - Schlüsselweite
AF - Ouverture de clé
AF - Ancho de llave

Adaptors

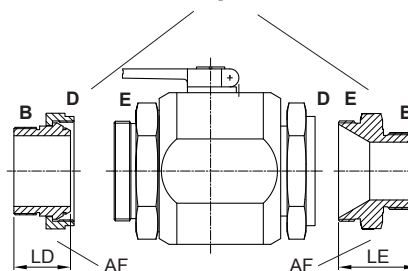

Adaptor EB

Size	E	B	*AF	LE	Typ No.
B3	M52x2	G1"	70	55	EB52.G1
	M52x2	G1 ¼"	70	54	EB52.G1.25
	M52x2	G1 ½"	70	52	EB52.G1.5
	M52x2	G2"	70	60	EB52.G2
	M65x2	G1 ½"	70	60	EB65.G1.5
B5	M65x2	G2"	70	52	EB65.G2
	M78x2	G2"	80	59	EB78.G2
	M78x2	G2 ½"	80	59	EB78.G2.5
	M78x2	NPT2 ½"	80	63	EB78.N2.5

Blain Hydraulics GmbH
Pfaffenstrasse 1
74078 Heilbronn
Germany
Tel. +49 7131 28210
Fax +49 7131 282199
www.blain.de
info@blain.de



Designer and Manufacturer of the highest quality control valves & safety components for hydraulic elevators



Ball Valves with EV Robinet à boisseau avec EV

3/4"



1 1/2" & 2"

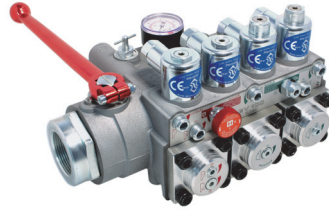

Kugelhähne mit EV Llaves esféricas con EV

BV

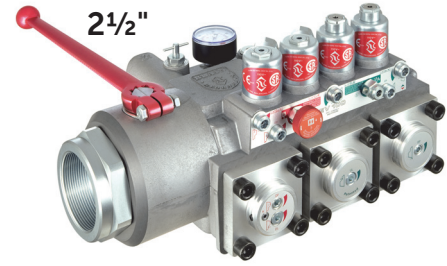

Standard Connection A

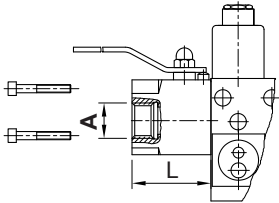

A	L	Typ No.
G (BSP) 1/2"	83	BG 0.5
G (BSP) 3/4"	58	BG .75
G (BSP) 1"	58	BG 1
NPT 3/4"	58	BN .75
NPT 1"	58	BN 1

* Reduction

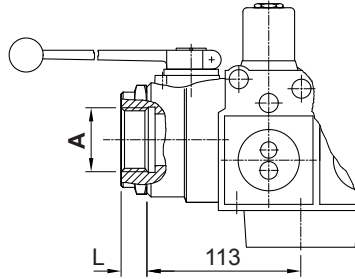

A	L	Typ No.
G (BSP) 1"	19	BG 1.0
G (BSP) 1 1/4"	21	BG 1.25
G (BSP) 1 1/2"	24	BG 1.5
G (BSP) 2"	30	BG 2
NPT 1"	28	BN 1
NPT 1 1/4"	28	BN 1.25
NPT 1 1/2"	34	BN 1.5
NPT 2"	34	BN 2

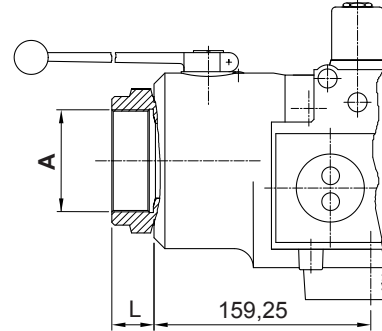

A	L	Typ No.
G (BSP) 2"	31	BG 2.0
G (BSP) 2 1/2"	31	BG 2.5
NPT 2"	31	BN 2.0
NPT 2 1/2"	35	BN 2.5

Optional Connection E

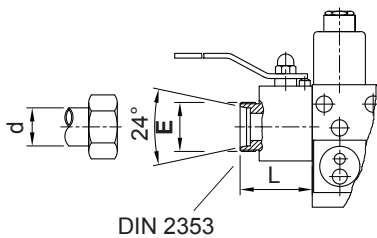

E	L	d	Typ No.
M 22x1.5	80	15	BM 22
M 30x2	54	22	BM 30
M 36x2	54	28	BM 36

* Reduction

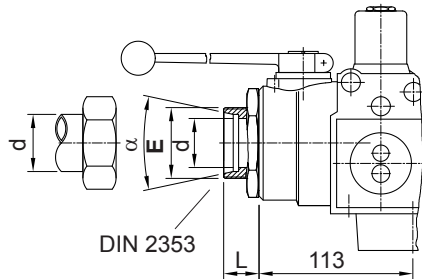

E	L	α	d	Typ No.
M 36x2	23	24°	28	BM 36.0
M 45x2	25	24°	35	BM 45
M 52x2	25	24°	42	BM 52

DIN 3863

E	L	α	Typ No.
M 65x2	26	60°	BM 65
M 78x2	37	60°	BM 78

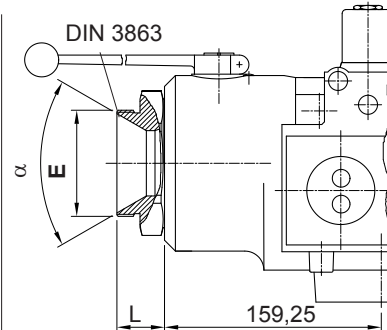

E	L	α	Typ No.
M78x2	35	60°	BM 78.0

Parts List

BG Grip
BP Limit Pin
BO Shaft O-Ring
BS Shaft
BL Limit Disc
BR Bearing ring
BA Connection
BQ Connection O-Ring
BH Housing
BB Ball
BT POM Seal

Stückliste

BG Griff
BP Kerbstift
BO O-Ring Schaltwelle
BS Schaltwelle
BL Arretierscheibe
BR Gleitring
BA Adapter
BQ O-Ring Adapter
BH Gehäuse
BB Kugel
BT POM Dichtung

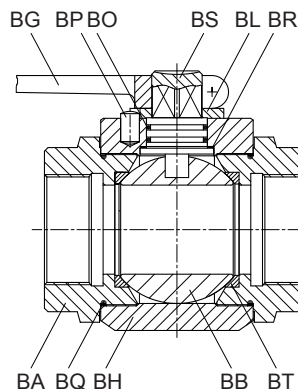

Liste des pièces

BG Levier
BP Goupille
BO O-Ring axe du levier
BS Axe du levier
BL Disque d'arrêt
BR Anneau de glissement
BA Connexion
BQ Connexion O-Ring
BH Cage
BB Boule
BT POM joint

Lista de piezas

BG Brazo
BP Pasador tope
BO Junta eje de giro
BS Eje de giro
BL Retén
BR Anillo deslizante
BA Conexión salida
BQ Junta conexión salida
BH Cuerpo
BB Bola
BT Junta de POM